



4 INPUT VOLTAGE-CURRENT ACQUISITION MODULE

Z-4AI-D

GENERAL SPECIFICATIONS

- **Interface for PLC on standard digital I/O (only DC).**
- DC voltage and current input up to +/- 10V DC, +/- 20 mA DC.
- Sampling time settable at 400 ms @ 14 bit + sign, 200 ms @ 13 bit + sign.
- Protection of inputs of up to 60V.
- 1500V AC input insulation with respect to remaining low voltage circuits.
- Facilitated wiring of the power supply and the serial bus by means of a bus that can be housed in the DIN guide as an alternative to the terminals.
- Connection distance up to 100 m (with shielded cable).

TECHNICAL SPECIFICATIONS

| | | | | | |
|-----------------------------|---|------------------|-----------------------|--------------------------|--------------|
| Power supply: | 19–40 DC, 19–28V AC, 50-60 Hz, max 2.5W; 1.0W @ 24V DC sensor power supply not included. | | | | |
| Communication port: | RS232 serial port on front panel can be used for the control and set-up of the module. | | | | |
| PLC communication: | 3-wire synchronous serial: CLOCK, DATA, STROBE, standard levels 24V pnp. | | | | |
| Voltage input: | Bipolar with f.s. +/-10V DC or +/- 2V DC, input impedance 100 Kohm, resolution 14 / 13 bit + sign. | | | | |
| Current input: | Bipolar with f.s. +/- 20 mA DC, input impedance 100 ohm, resolution 14 / 13 bit + sign. | | | | |
| Sensor power supply: | Sensor power supply 20V DC, 40 mA max, protected against overload. | | | | |
| Errors: | Calibration | Linearity | Zero stability | Thermal stability | Other |
| Voltage | 0.1% o.m. | 0.02% o.s. | 0.02% o.s. | 0.01%/°C o.m. | 1% o.s. (1) |
| Current | 0.2% o.m. | 0.02% o.s. | 0.02% o.s. | 0.01%/°C o.m. | 1% o.s. (1) |
| Ambient conditions: | Temperature: 0..55°C, min. humidity: 30%, max 90% at 40°C non-condensing | | | | |
| Protection rating: | IP20 | | | | |
| Weight, dimensions: | 140g, 100 x 112 x 17.5 mm. | | | | |
| Standards |  <p>The instrument complies with the following standards: EN50081-2 (electromagnetic emission, industrial environment) EN50082-2 (electromagnetic immunity, industrial environment) EN61010-1 (safety) All the circuits must be provided with double insulation against circuits under dangerous voltage. The power supply transformer must comply with EN60742 standards for insulation transformers and safety transformers.</p> | | | | |

(1) for any electromagnetic interference present

IMPORTANT

A program known as Z-PROG can be downloaded from the www.seneca.it site for the initial programming and testing of the product

INSTALLATION

The module has been designed for vertical installation on a DIN 46277 guide.
 For optimal operation and long life, adequate ventilation must be provided for the module(s), avoiding positioning channels that obstruct the ventilation louvers.
 Avoid fitting modules above equipment that generates heat; you are advised to fit them at the bottom of the panel.

HARSH OPERATING CONDITIONS:

When the modules are fitted side by side it may be **necessary to separate them by at least 5 mm** if the panel temperature is above 45°C and operating conditions are harsh.

The following constitute harsh operating conditions:

- High power supply voltage (> 30Vdc / > 26 V AC).
- Power supply for sensors with high consumption (> 20 mA).

NOTE: Use of the DIN guide connectors supplied on request ensures practical fitting and correct ventilation of the modules, in addition to reducing the number of electrical cables.

ELECTRICAL CONNECTIONS

POWER SUPPLY

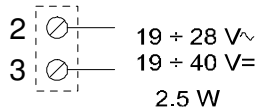

The power supply voltage must be between 19 and 40 Vdc (any polarity) or 19 and 28 V AC; see also section **INSTALLATION**.

The upper limits must not be exceeded as this can seriously damage the module.

The power supply source must be protected from any failures in the module by means of a suitably sized fuse. The module can be powered via the DIN guide connectors.

MEASUREMENT INPUTS

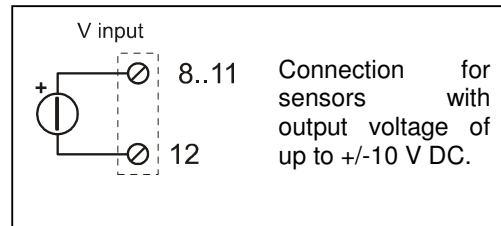
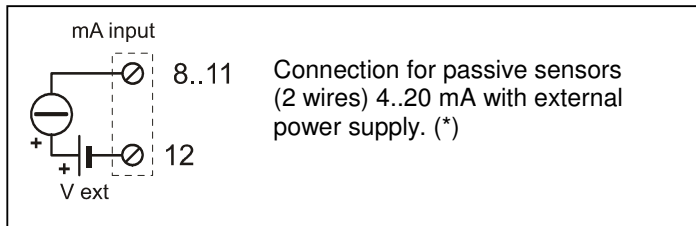
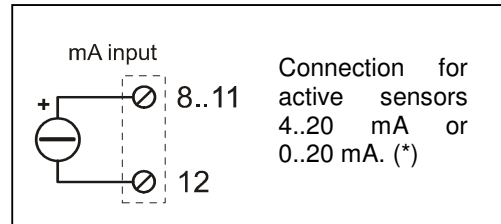
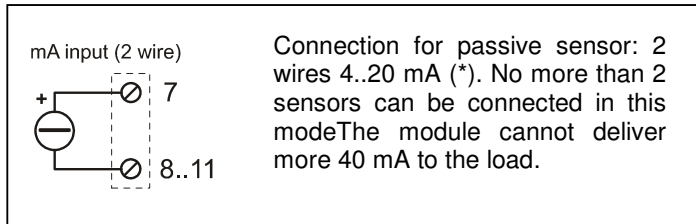

(*) in order to utilise the input as current, the respective dip-switch must be ON. This operation connects a 100 Ohm resistance parallel to the input terminals and permits a signal of +/- 2000 mV to be obtained near +/- 20 mA.

The PLC interface is based on three PNP-type signals suited for connection to most PLCs available in the market.

The interface is composed of a CLOCK signal generated by the PLC (transistor output), a DATA signal and STROBE signal generated by the module. At each program cycle, the PLC switches a CLOCK signal (see time diagram); the module, in turn presents a bit sequence of the max. 80 foreseen, 16 for each complete datum on the DATA output.

The module also generates a STROBE signal towards the end of the bit sequence that informs the PLC that the data are complete; the PLC must enter in a scanning register the **status of the DATA signal corresponding to the negative commutation of the CLOCK signal** (in this moment, the signal is certainly valid, also bearing in mind the time of the input's delay. When the STROBE signal is positive, the data are complete and can be memorised.

In this way any PLC can easily read the 4 analogue channels available with refresh times comparable to the module's own acquisition times. The acquisition time can be calculated as follows: PLC cycle time x the number of channels x 32; if the cycle time is 5 ms for example, the acquisition time will be 640 ms.

The programming necessary for the PLC is extremely reduced: the SIEMENS S7-200 PLC requires one 10 lines of Ladder Diagram (see enclosure) in order to read the analogue inputs; this corresponds to approx. 187 byte of programming space.

It is not necessary to read all the channels: the **Z-PROG** programming tool can be used to decide which channels to be sent to the PLC. The tool also permits the selection of the module's various operating modes: field of measurement, filter, type of serialisation, type of datum sent to the PLC, etc.

PLC CONNECTIONS

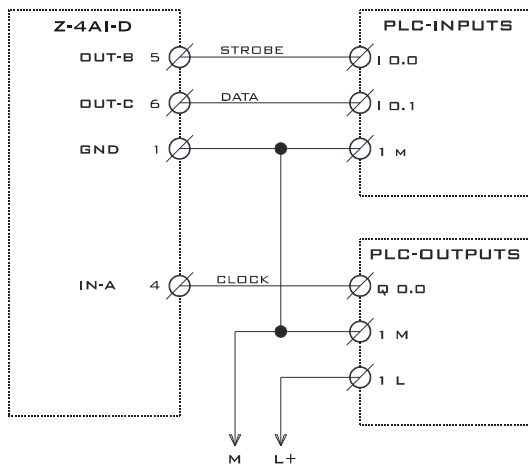

Although the connections indicated regard a SIEMENS S7-200 CPU 224-DC/DC/DC PLC in particular, other PLCs can also be used provided that their inputs are fast enough (< 2 ms) and their outputs are transistor and not relay type).

TIMING DIAGRAM

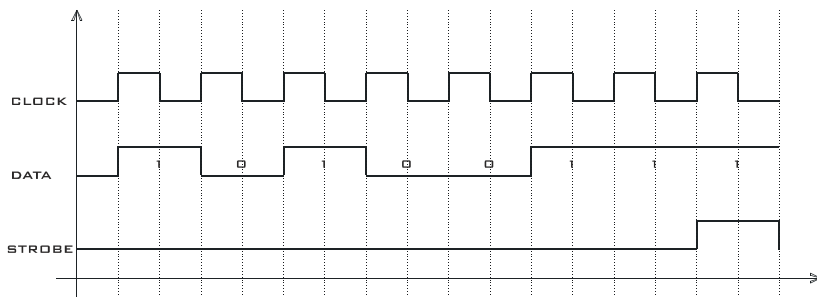

SETTING THE DIP-SWITCHES

One side of the module features the dip-switches which are useful for selecting the following functions: see the table below:

SW1:



In order to use the input as current, the respective dip-switch must be set in ON. The 100 Ohm resistance permits the 4..20 mA signal to be converted into 0.4..2V voltage that can be read by the module.

| <i>Dip-switch</i> | <i>Status</i> | <i>Function</i> |
|-------------------|---------------|--|
| SW1.1 | ON | connects 100 Ohm resistance on channel 1 |
| SW1.2 | ON | connects 100 Ohm resistance on channel 2 |
| SW1.3 | ON | connects 100 Ohm resistance on channel 3 |
| SW1.4 | ON | connects 100 Ohm resistance on channel 4 |

PROGRAMMING AND DESCRIPTION OF INTERNAL REGISTERS

The **Z-PROG** programming tool permits the setting of the Z-4TC-D module for operating adaptation to the needs of the user. The use of the tool requires the connection cable between the PC and the module which can be purchased directly from SENECA (code Z-PC). The cable jack must be inserted in the outlet on the front of the module; during programming, the module must be switched on.

The table below describes the internal registers that can be modified and/or read with the use of the tool;

some of these are the same that are read by the PLC, ad the latter are distinguished by the symbol which indicates that they can be read by the PLC. For reasons of space, the registers for channels 2,3,4 have not been listed because they are the same for all the channels.

| | | |
|--|-------------------------------|---|
| | Input 1.Filter 0..6 | Measurement filter, values can be set from 0 to 6, corresponding to: 0 = no filter, 1 = minimum filter.... 6 = maximum filter. |
| | Input 1.Full Scale | Full scale measurement value in mV; ; whenever the value measured reaches the value set in FSCALEx, the NCHx register assumes the value of 10000. |
| | Input 1.Init Scale | Start of measurement scale in mV; whenever the value measured reaches the value set in ISCALEx, the NCHx register assumes the value of 0. |
| | STATUS | Status indicator flags, see below for details. |
| | Input 1.Scaled Input | Channel measurement value with scale 0..10000, normalised at the span and zero set using FSCALEx and ISCALEx. |
| | Input 1. Raw Input | Channel measurement value with scale +/- 0..16000 not normalised. The full scale used - which can be 2000 mV or 10V DC. Depends on FSCALEx and ISCALEx. |

Details of the register

STATUS: This register must be considered in binary format, i.e. each active bit (=1) of the register corresponds to an error or warning status.

The table shows the functions associated with each bit.

| | Signalling: |
|----|--|
| .0 | None |
| .1 | None |
| .2 | =1: EEPROM programming error. Active if the last programming of an EEPROM register has failed. |

| | |
|-----|--|
| .3 | =1: data programming error. Active if the setting of the type of input or value of the filter is not included in the range of acceptability. |
| .4 | None |
| .5 | None |
| .6 | None |
| .7 | None |
| .8 | =1: if the channel 1 measurement is higher than the maximum positive value permitted for the type of input selected |
| .9 | =1: if the channel 1 measurement is lower than the maximum positive value permitted for the type of input selected |
| .10 | =1: if the channel 2 measurement is higher than the maximum positive value permitted for the type of input selected |
| .11 | =1: if the channel 2 measurement is lower than the maximum positive value permitted for the type of input selected |
| .12 | =1: if the channel 3 measurement is higher than the maximum positive value permitted for the type of input selected |
| .13 | =1: if the channel 3 measurement is lower than the maximum positive value permitted for the type of input selected |
| .14 | =1: if the channel 4 measurement is higher than the maximum positive value permitted for the type of input selected |
| .15 | =1: if the channel 4 measurement is lower than the maximum positive value permitted for the type of input selected |

As regards PLC interface instead, the panel **PLC Interface Settings** can be used to select the channels to be read by the PLC, the type of datum (Scaled or Raw), the inversion of the bit sequence (normally the first is the most significant bit), and the increase of the conversion speed. Consult the on-line guide for the use of the tool.

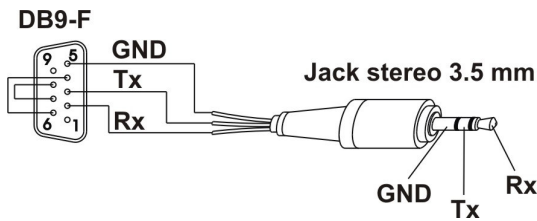

Z-PC cable creation diagram for programming by PC. This cable can be ordered as an accessory.

OVERALL DIMENSIONS

